

MONOLITHIC REFRACTORIES ALUMINUM

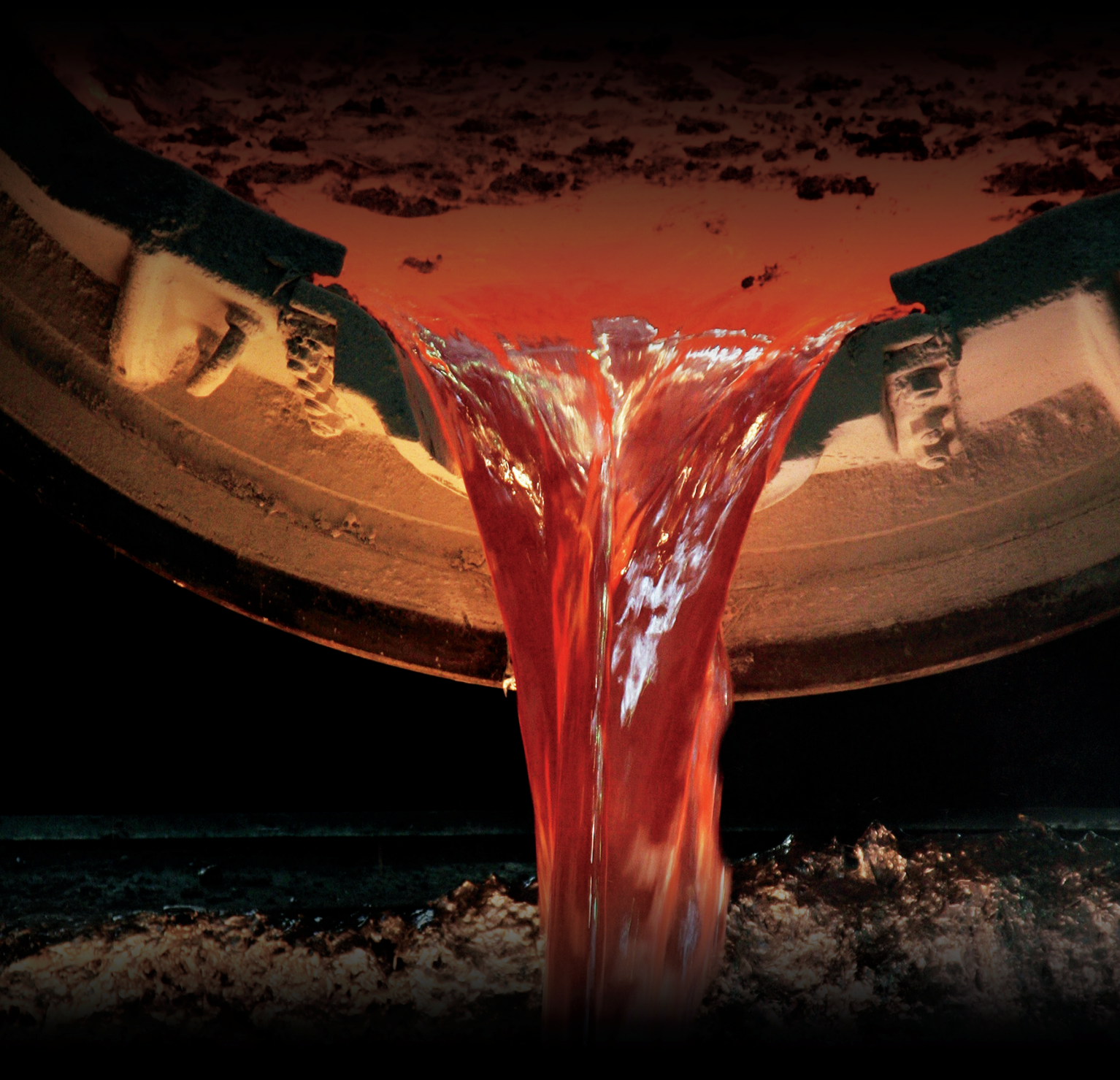

DIE CUT

Monolithic Refractories for Metalcasting, Minerals Processing, Power Generation and Petrochemical Industries

United Refractories Company (URC) designs innovative, durable refractories focusing on customer specific needs and applications. Our technically driven products manufactured at our UNI-REF, Inc. (URI) facility include our UNI-RAM VR dry vibratables for induction furnaces, cutting edge cupola products, Rapid Fire accelerated dry-out technology, and UNI-SHOT/UNI-BRADE abrasion resistant refractory products. 40 years providing unparalleled value through outstanding quality, proven technology and customer focused service.



Quality means more than our ISO9001:2008 certification - we go even further. It's not just our standard, quality is our commitment.

Visit us at www.unitedrefractoriesco.com to learn more.

STRATEGICALLY LOCATED TO SERVE YOU BETTER...

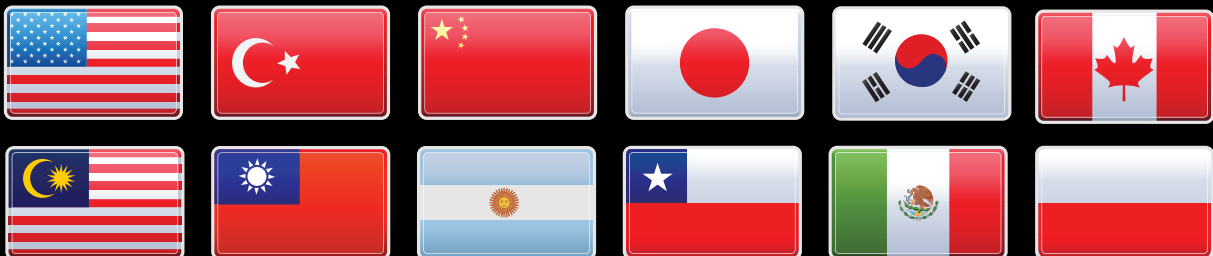

Currently represented in 30 countries and across 5 continents with manufacturing plants in USA, China, Taiwan and Japan. With strategic partners located throughout the world, United Refractories Co. is committed to servicing our customers. Our commitment to partnering with distributors and licensees allows us to continue to grow our global presence.

ALUMINUM REFRACTORIES
REVERBERATORY
STACK MELTER
ROTARY, DIE CASTING
TRANSFER & MAINTENANCE



REVERBERATORY

STACK MELTER

ROTARY, DIE CASTING, TRANSFER & MAINTENANCE

ALUMINUM REFRACTORIES REVERBERATORY

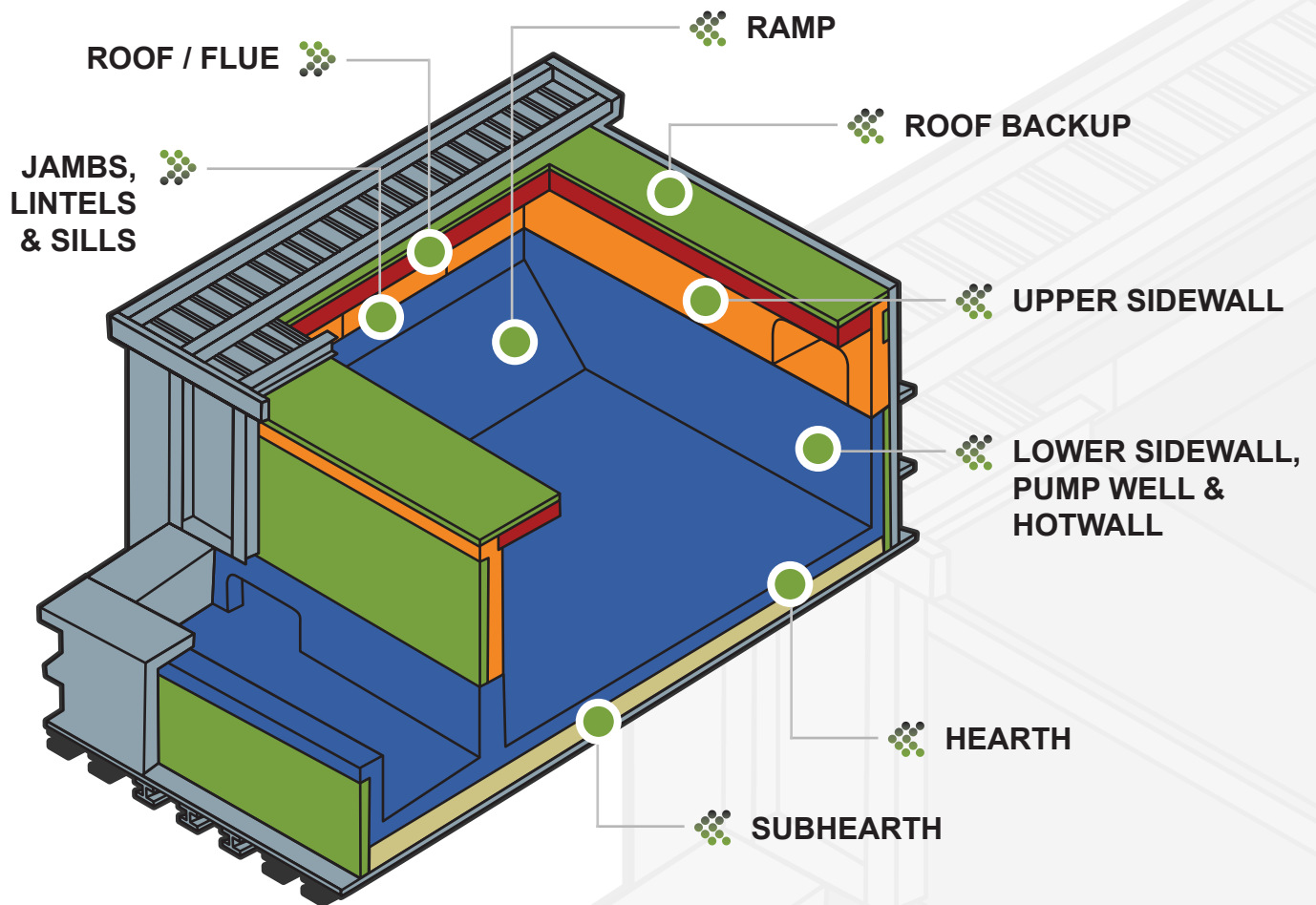

REVERBERATORY

| LOWER SIDEWALL, PUMP WELL, HOTWALL | MAXIMUM TEMP. | | MATERIAL REQ'D | | CHEMICAL ANALYSIS % | | | |
|---------------------------------------|---------------|------|---------------------|-------------------|--------------------------------|------------------|-----|----------------------|
| | °F | °C | Lbs/ft ³ | Kg/m ³ | Al ₂ O ₃ | SiO ₂ | CaO | Other |
| UNI-PUMP LC-80HSA | 3200 | 1760 | 183 | 2930 | 82.5 | 11.8 | 2.1 | 3.6 |
| UNI-CAST LC-80HSA | 3200 | 1760 | 183 | 2930 | 79.9 | 12.0 | 2.1 | 6.0 |
| UNI-PUMP LC-65HSA | 3150 | 1730 | 163 | 2610 | 64.5 | 30.8 | 2.0 | 2.7 |
| UNI-PUMP ML-69CA | 3050 | 1680 | 158 | 2530 | 64.2 | 29.1 | 1.3 | 5.4 |
| UNI-CAST LC-65PA | 3100 | 1700 | 165 | 2640 | 63.1 | 30.0 | 1.3 | 5.6 |
| UNI-CAST ML-69CA | 3100 | 1700 | 158 | 2530 | 61.9 | 31.3 | 1.2 | 5.6 |
| UNI-PUMP 60A | 3100 | 1700 | 153 | 2450 | 59.0 | 36.5 | 2.0 | 2.5 |
| UNI-PUMP LC-50HZA | 3000 | 1650 | 161 | 2580 | 48.5 | 35.6 | 2.6 | 8.9 ZrO ₂ |
| UNI-CAST LC-60SCA | 2900 | 1590 | 163 | 2610 | 24.0 | 12.3 | 1.5 | 61.1 SiC |

| UPPER SIDEWALL | MAXIMUM TEMP. | | MATERIAL REQ'D | | CHEMICAL ANALYSIS % | | | |
|--|---------------|------|---------------------|-------------------|------------------------------------|------------------------|------------|-----------------------------------|
| | °F | °C | Lbs/ft ³ | Kg/m ³ | Al ₂ O ₃ | SiO ₂ | CaO | Other |
| UNI-CAST LC-80HSA | 3200 | 1760 | 183 | 2930 | 79.9 | 12.0 | 2.1 | 6.0 |
| UNI-PUMP ML-69CA | 3050 | 1680 | 158 | 2530 | 64.2 | 29.1 | 1.3 | 5.4 |
| UNI-CAST LC-65PA | 3100 | 1700 | 165 | 2640 | 63.1 | 30.0 | 1.3 | 5.6 |
| UNI-CAST ML-69CA | 3100 | 1700 | 158 | 2530 | 61.9 | 31.3 | 1.2 | 5.6 |
| UNI-PUMP 60 | 3100 | 1700 | 153 | 2450 | 59.0 | 36.5 | 2.0 | 2.5 |
| UNI-CAST 3000 | 3000 | 1650 | 130 | 2080 | 51.6 | 40.9 | 4.6 | 2.9 |
| UNI-PUMP 45 | 2950 | 1620 | 148 | 2370 | 50.4 | 44.3 | 3.0 | 2.3 |
| UNI-CAST 2600A | 2600 | 1430 | 133 | 2130 | 48.4 | 37.8 | 9.6 | 4.2 |
| JAMBS, LINTELS, RAMPS AND SILLS | | | | | Al₂O₃ | SiO₂ | CaO | Other |
| UNI-PUMP LC-80HSA | 3200 | 1760 | 183 | 2930 | 82.5 | 11.8 | 2.1 | 3.6 |
| UNI-PUMP LC-65HSA | 3150 | 1730 | 163 | 2610 | 64.5 | 30.8 | 2.0 | 2.7 |
| UNI-PUMP ML-69CA | 3050 | 1680 | 158 | 2530 | 64.2 | 29.1 | 1.3 | 5.4 |
| UNI-CAST LC-65PA | 3100 | 1700 | 165 | 2640 | 63.1 | 30.0 | 1.3 | 5.6 |
| UNI-CAST LC-60SCA | 2900 | 1590 | 163 | 2610 | 24.0 | 12.3 | 1.5 | 61.1 sic |
| BURNER BLOCKS, TAP HOLE BLOCKS | | | | | Al₂O₃ | SiO₂ | CaO | Other |
| UNI-CAST LC-94 | 3300 | 1820 | 195 | 3120 | 93.3 | 4.7 | 1.5 | 0.5 |
| UNI-CAST LC-65PA | 3100 | 1700 | 165 | 2640 | 63.1 | 30.0 | 1.3 | 5.6 |
| UNI-CAST ML-69CA | 3100 | 1700 | 158 | 2530 | 61.9 | 31.3 | 1.2 | 5.6 |
| UNI-CAST 2600A | 2600 | 1430 | 133 | 2130 | 48.4 | 37.8 | 9.6 | 4.2 |
| UNI-CAST LC-60SCA | 2900 | 1590 | 163 | 2610 | 24.0 | 12.3 | 1.5 | 61.1 sic |
| UNI-RAM 85ESS A | 3200 | 1760 | 180 | 2880 | 74.9 | 16.2 | - | 3.6 P ₂ O ₅ |
| UNI-RAM BLU J-A | 3100 | 1700 | 170 | 2720 | 68.5 | 25.6 | - | 3.7 P ₂ O ₅ |
| HEARTH / SUBHEARTH | | | | | Al₂O₃ | SiO₂ | CaO | Other |
| UNI-PUMP LC-65HSA | 3150 | 1730 | 163 | 2610 | 64.5 | 30.8 | 2.0 | 2.7 |
| UNI-PUMP ML-69CA | 3050 | 1680 | 158 | 2530 | 64.2 | 29.1 | 1.3 | 5.4 |
| UNI-CAST LC-65PA | 3100 | 1700 | 165 | 2640 | 63.1 | 30.0 | 1.3 | 5.6 |
| UNI-CAST ML-69CA | 3100 | 1700 | 158 | 2530 | 61.9 | 31.3 | 1.2 | 5.6 |
| UNI-PUMP 45 | 2950 | 1620 | 148 | 2370 | 50.4 | 44.3 | 3.0 | 2.3 |
| PUMP-CAST 50C | 2900 | 1590 | 143 | 2290 | 50.0 | 44.8 | 2.4 | 2.8 |
| UNI-CAST 2400C | 2450 | 1340 | 128 | 2050 | 42.7 | 43.7 | 9.6 | 4.0 |
| ROOF / FLUE | | | | | Al₂O₃ | SiO₂ | CaO | Other |
| UNI-PUMP ML-69CA | 3050 | 1680 | 158 | 2530 | 64.2 | 29.1 | 1.3 | 5.4 |
| PUMP-CAST 60 | 3050 | 1680 | 155 | 2480 | 54.6 | 41.4 | 1.6 | 2.4 |
| UNI-PUMP 45 | 2950 | 1620 | 148 | 2370 | 50.4 | 44.3 | 3.0 | 2.3 |
| PUMP-CAST 50C | 2900 | 1590 | 143 | 2290 | 50.0 | 44.8 | 2.4 | 2.8 |
| UNI-CAST 2600A | 2600 | 1430 | 133 | 2130 | 48.4 | 37.8 | 9.6 | 4.2 |
| UNI-CAST 2400CA | 2450 | 1340 | 128 | 2050 | 41.3 | 42.3 | 9.3 | 7.1 |

ALUMINUM REFRACTORIES

STACK MELTER

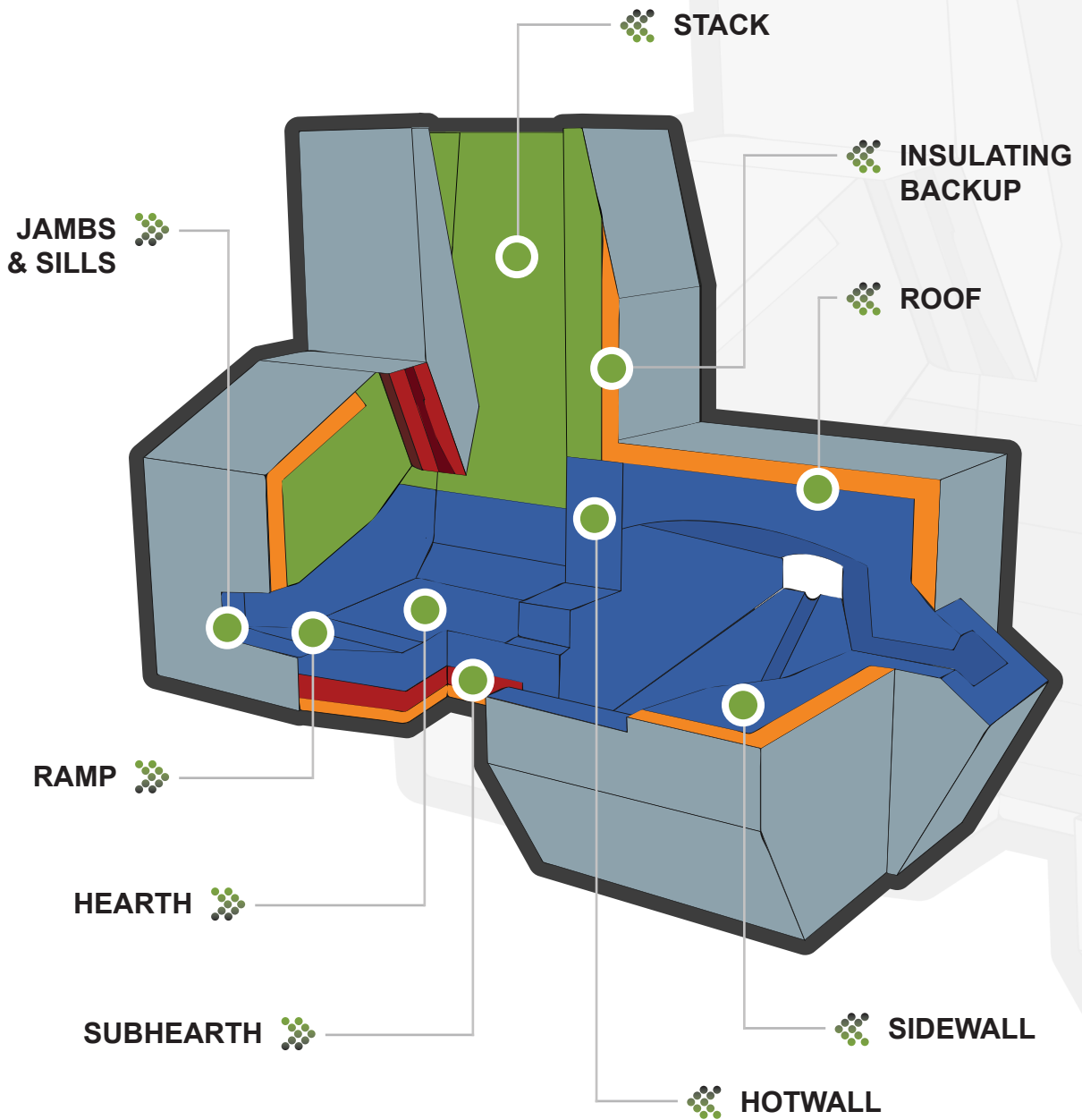

STACK MELTER

STACK MELTER

| STACK | MAXIMUM TEMP. | | MATERIAL REQ'D | | CHEMICAL ANALYSIS % | | | |
|--|---------------|------|---------------------|-------------------|------------------------------------|------------------------|------------|----------------------|
| | °F | °C | Lbs/ft ³ | Kg/m ³ | Al ₂ O ₃ | SiO ₂ | CaO | Other |
| UNI-PUMP LC-80HSA | 3200 | 1760 | 183 | 2930 | 82.5 | 11.8 | 2.1 | 3.6 |
| UNI-CAST ML-77A | 3300 | 1820 | 158 | 2530 | 67.5 | 25.0 | 1.4 | 6.1 |
| UNI-PUMP ML-69CA | 3050 | 1680 | 158 | 2530 | 64.2 | 29.1 | 1.3 | 5.4 |
| UNI-PUMP RF-60Z | 3100 | 1700 | 152 | 2435 | 56.0 | 35.6 | 2.6 | 3.3 ZrO ₂ |
| UPPER SIDEWALL | | | | | Al₂O₃ | SiO₂ | CaO | Other |
| UNI-PUMP LC-65PA | 3100 | 1700 | 165 | 2640 | 65.5 | 30.6 | 1.0 | 2.9 |
| UNI-PUMP ML-69CA | 3050 | 1680 | 158 | 2530 | 64.2 | 29.1 | 1.3 | 5.4 |
| UNI-PUMP 45 | 2950 | 1620 | 148 | 2370 | 50.4 | 44.3 | 3.0 | 2.3 |
| LOWER SIDEWALL, JAMBS, LINTELS, RAMPS & SILLS | | | | | Al₂O₃ | SiO₂ | CaO | Other |
| UNI-PUMP LC-80HSA | 3200 | 1760 | 183 | 2930 | 82.5 | 11.8 | 2.1 | 3.6 |
| UNI-CAST ML-77A | 3300 | 1820 | 158 | 2530 | 67.5 | 25.0 | 1.4 | 6.1 |
| UNI-PUMP ML-69CA | 3050 | 1680 | 158 | 2530 | 64.2 | 29.1 | 1.3 | 5.4 |
| BURNER BLOCKS, TAP HOLE BLOCKS | | | | | Al₂O₃ | SiO₂ | CaO | Other |
| UNI-CAST ML-69CA | 3100 | 1700 | 158 | 2530 | 61.9 | 31.3 | 1.2 | 5.6 |
| PUMP-CAST 60A | 3050 | 1680 | 155 | 2485 | 58.6 | 37.2 | 1.5 | 2.7 |
| HEARTH / SUBHEARTH | | | | | Al₂O₃ | SiO₂ | CaO | Other |
| UNI-PUMP LC-80HSA | 3200 | 1760 | 183 | 2930 | 82.5 | 11.8 | 2.1 | 3.6 |
| UNI-CAST ML-77A | 3300 | 1820 | 158 | 2530 | 67.5 | 25.0 | 1.4 | 6.1 |
| UNI-PUMP ML-69CA | 3050 | 1680 | 158 | 2530 | 64.2 | 29.1 | 1.3 | 5.4 |
| UNI-CAST LW-80G* | 2500 | 1370 | 85 | 1360 | 44.1 | 39.8 | 11.6 | 4.5 |
| UNI-CAST 2400CA* | 2450 | 1340 | 128 | 2050 | 41.3 | 42.3 | 9.3 | 7.1 |
| *Subhearth only | | | | | | | | |
| ROOF | | | | | Al₂O₃ | SiO₂ | CaO | Other |
| UNI-CAST ML-69CA | 3100 | 1700 | 158 | 2530 | 61.9 | 31.3 | 1.2 | 5.6 |
| UNI-PUMP 45 | 2950 | 1620 | 148 | 2370 | 50.4 | 44.3 | 3.0 | 2.3 |

ALUMINUM REFRACTORIES

ROTARY, DIE CASTING, TRANSFER & MAINTENANCE

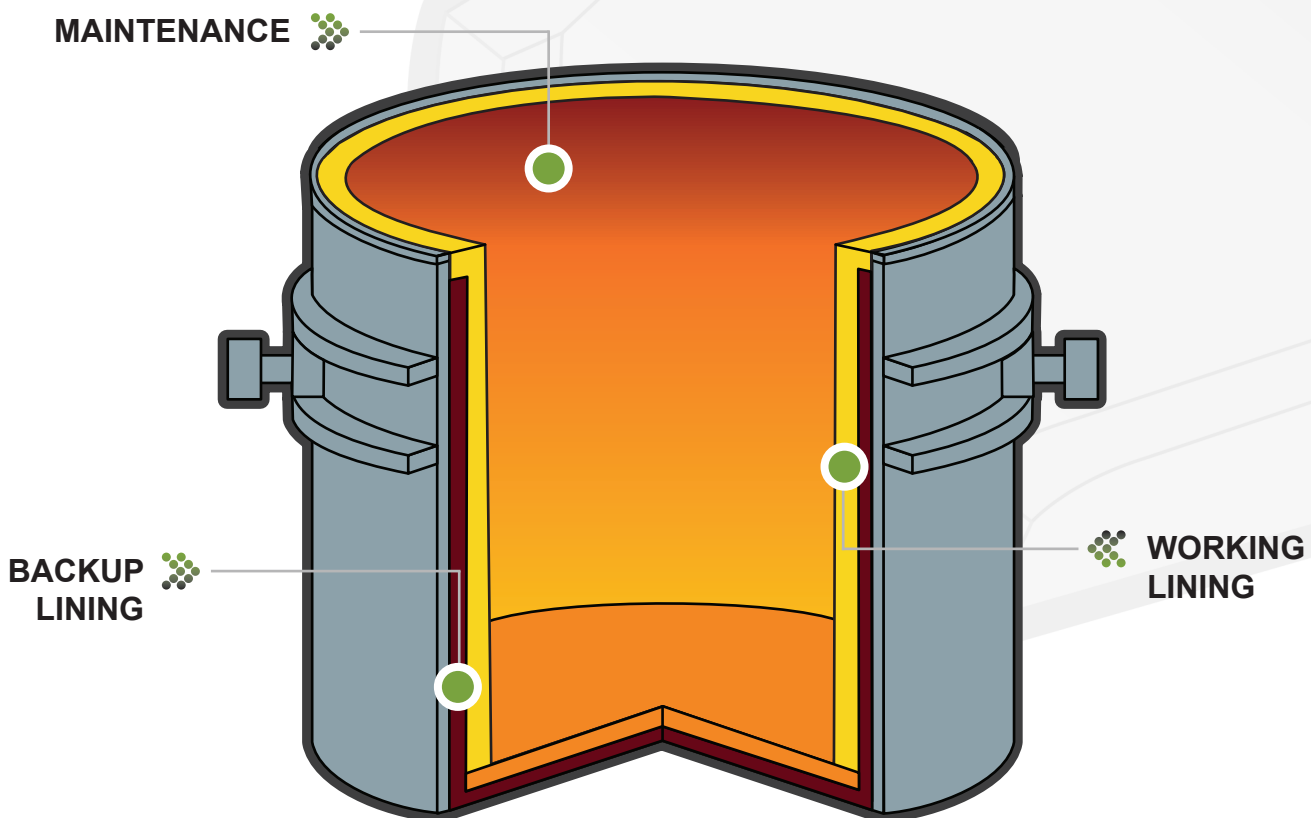
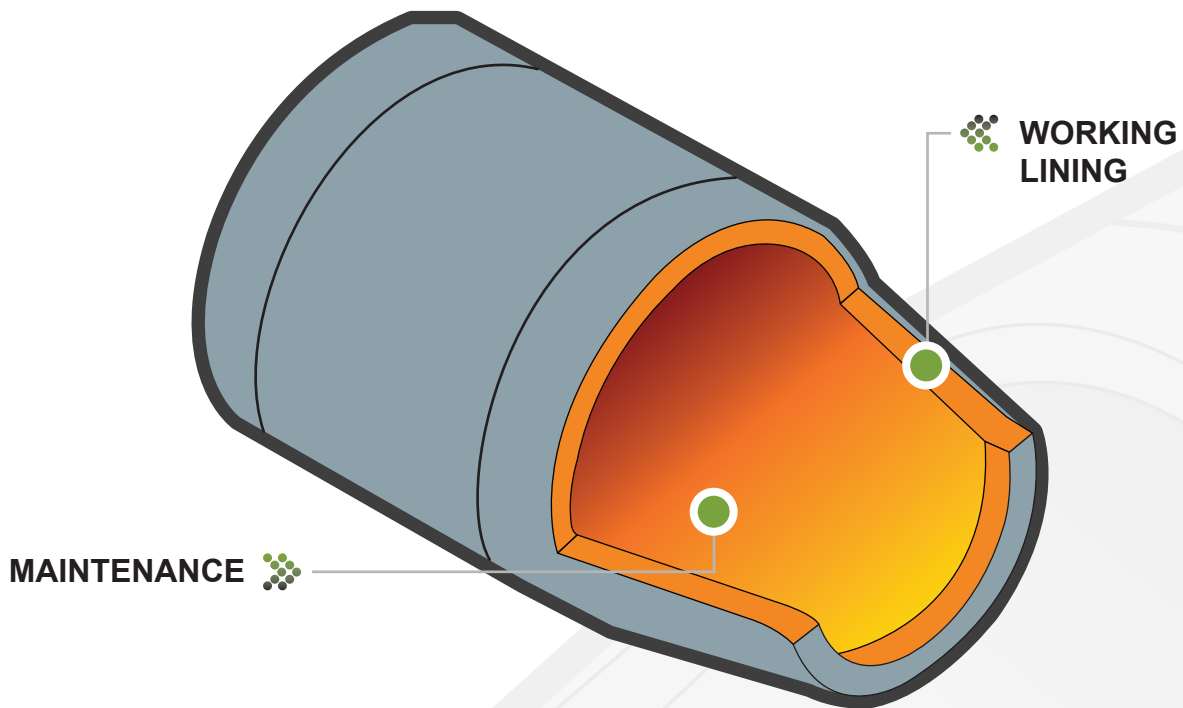

ROTARY

| WORKING LINING | MAXIMUM TEMP. | | MATERIAL REQ'D | | CHEMICAL ANALYSIS % | | | |
|----------------------|---------------|------|---------------------|-------------------|--------------------------------|------------------|-----|-----------------------------------|
| | °F | °C | Lbs/ft ³ | Kg/m ³ | Al ₂ O ₃ | SiO ₂ | CaO | Other |
| UNI-PUMP LC-80HSA | 3200 | 1760 | 183 | 2930 | 82.5 | 11.8 | 2.1 | 3.6 |
| UNI-PUMP LC-85A | 3300 | 1820 | 178 | 2850 | 81.9 | 9.8 | 1.4 | 6.9 |
| UNI-PUMP LC-65PA | 3100 | 1700 | 165 | 2640 | 65.5 | 30.6 | 1.0 | 2.9 |
| UNI-PUMP ML-69CA | 3050 | 1680 | 158 | 2530 | 64.2 | 29.1 | 1.3 | 5.4 |
| MAINTENANCE PRODUCTS | | | | | Al ₂ O ₃ | SiO ₂ | CaO | Other |
| UNI-GUN 70A | 3100 | 1700 | 153 | 2450 | 69.8 | 22.4 | 3.8 | 4.0 |
| UNI-GUN 65A | 3100 | 1700 | 163 | 2610 | 63.2 | 27.2 | 3.7 | 5.9 |
| UNI-GUN RF-65RGA | 3100 | 1700 | 143 | 2290 | 63.1 | 28.1 | 2.8 | 6.0 |
| UNI-SHOT 65A | 3150 | 1730 | 163 | 2610 | 61.0 | 31.6 | 2.0 | 5.4 |
| UNI-RAM 85ESS A | 3200 | 1760 | 180 | 2880 | 74.9 | 16.2 | - | 3.6 P ₂ O ₅ |
| UNI-RAM F-A | 3000 | 1650 | 157 | 2520 | 50.1 | 41.9 | - | 3.4 P ₂ O ₅ |

LOW PRESSURE DIE CASTING

| WORKING LINING | MAXIMUM TEMP. | | MATERIAL REQ'D | | CHEMICAL ANALYSIS % | | | |
|------------------|---------------|------|---------------------|-------------------|--------------------------------|------------------|------|-------|
| | °F | °C | Lbs/ft ³ | Kg/m ³ | Al ₂ O ₃ | SiO ₂ | CaO | Other |
| UNI-CAST ML-77A | 3300 | 1820 | 158 | 2530 | 67.5 | 25.0 | 1.4 | 6.1 |
| UNI-PUMP ML-69CA | 3050 | 1680 | 158 | 2530 | 64.2 | 29.1 | 1.3 | 5.4 |
| UNI-CAST LC-65PA | 3100 | 1700 | 165 | 2640 | 63.1 | 30.0 | 1.3 | 5.6 |
| SAFETY LINING | | | | | Al ₂ O ₃ | SiO ₂ | CaO | Other |
| UNI-CAST 2400C | 2450 | 1340 | 128 | 2050 | 42.7 | 43.7 | 9.6 | 4.0 |
| UNI-CAST LW-80G | 2500 | 1370 | 85 | 1360 | 44.1 | 39.8 | 11.6 | 4.5 |
| UNI-CAST LW-60G | 2300 | 1260 | 62 | 995 | 31.2 | 46.2 | 14.2 | 8.4 |

TRANSFER & MAINTENANCE

| CASTABLES | MAXIMUM TEMP. | | MATERIAL REQ'D | | CHEMICAL ANALYSIS % | | | |
|---|---------------|------|---------------------|-------------------|------------------------------------|------------------------|-----------------------------------|--------------|
| | °F | °C | Lbs/ft ³ | Kg/m ³ | Al ₂ O ₃ | SiO ₂ | CaO | Other |
| UNI-CAST LC-80HSA | 3200 | 1760 | 183 | 2930 | 79.9 | 12.0 | 2.1 | 6.0 |
| UNI-CAST ML-77A | 3300 | 1820 | 158 | 2530 | 67.5 | 25.0 | 1.4 | 6.1 |
| UNI-CAST LC-65PA | 3100 | 1700 | 165 | 2640 | 63.1 | 30.0 | 1.3 | 5.6 |
| UNI-CAST ML-69CA | 3100 | 1700 | 158 | 2530 | 61.9 | 31.3 | 1.2 | 5.6 |
| UNI-CAST 28ALW-HS | 2800 | 1540 | 115 | 1840 | 46.2 | 46.4 | 4.5 | 2.9 |
| UNI-CAST 2400CA | 2450 | 1340 | 128 | 2050 | 41.3 | 42.3 | 9.3 | 7.1 |
| UNI-CAST 25-75A | 2500 | 1370 | 75 | 1200 | 37.8 | 44.7 | 7.7 | 9.8 |
| UNI-CAST FS-6A | 2300 | 1260 | 135 | 2160 | 24.7 | 68.2 | 1.4 | 5.7 |
| UNI-CAST FSA | 2000 | 1090 | 120 | 1920 | 3.5 | 91.7 | 1.5 | 3.3 |
| UNI-CAST LW-80G | 2500 | 1370 | 85 | 1360 | 44.1 | 39.8 | 11.6 | 4.5 |
| UNI-CAST LW-60G | 2300 | 1260 | 62 | 995 | 31.2 | 46.2 | 14.2 | 8.4 |
| UNI-CAST LW-35G | 2000 | 1090 | 37 | 595 | 29.6 | 49.5 | 13.8 | 7.1 |
| UNI-CAST LC-80SCA | 3100 | 1700 | 165 | 2640 | 12.7 | 5.9 | 1.4 | 76.3 sic |
| UNI-CAST LC-60SCA | 2900 | 1590 | 163 | 2610 | 24.0 | 12.3 | 1.5 | 61.1 sic |
| GUNNING MIXES | | | | | Al₂O₃ | SiO₂ | CaO | Other |
| UNI-GUN 80HGA | 3200 | 1760 | 148 | 2370 | 79.6 | 14.9 | 1.6 | 3.9 |
| UNI-GUN 70HGA | 3150 | 1730 | 143 | 2290 | 73.0 | 18.3 | 1.6 | 7.1 |
| UNI-GUN 65A | 3100 | 1700 | 163 | 2610 | 63.2 | 27.2 | 3.7 | 5.9 |
| UNI-GUN RF-65RGA | 3100 | 1700 | 143 | 2290 | 63.1 | 28.1 | 2.8 | 6.0 |
| PLASTICS, SOFT PLASTICS & PLASTERS | | | | | Al₂O₃ | SiO₂ | P₂O₅ | Other |
| UNI-RAM 85ESS A | 3200 | 1760 | 180 | 2880 | 74.9 | 16.2 | 3.6 | 5.3 |
| UNI-RAM BLU J-A | 3100 | 1700 | 170 | 2720 | 68.5 | 25.6 | 3.7 | 2.2 |
| UNI-PLAS 85ESSA | 3200 | 1760 | 168 | 2690 | 76.5 | 16.1 | 3.7 | 3.7 |
| UNI-PLAS BLU J-A | 3100 | 1700 | 170 | 2720 | 67.2 | 25.9 | 4.1 | 2.8 |
| UNI-RAM 85C PLASTER | 3200 | 1760 | 180 | 2880 | 73.9 | 19.2 | 3.7 | 3.2 |
| UNI-RAM BLU FINE PLASTER | 3100 | 1700 | 160 | 2565 | 61.5 | 32.5 | 3.6 | 2.4 |

QUALITY TECHNOLOGY SERVICE

PERFORMANCE DESIGNED SOLUTIONS...

Customers need refractory to perform effectively throughout their life cycle demands. We offer more than a product recommendation -- URC provides the total package combining excellent service with a specific solution designed to meet or exceed your expectations. Our refractory products and our people represent Performance Designed Solutions grounded in quality, anchored by technology and supported by customer service that is second to none.

QUALITY...

Consistently creating and providing high impact products that help customers meet and exceed their specific refractory requirements. We put a premium on product consistency, ease of installation and rapid turnaround time. Our products are all pre-tested and must meet our internal specifications (and any third party testing demands) before being released for shipment. We have maintained certification to a Quality Management System since 1999, and are currently certified to the ISO 9001:2008 standard.



Quality means more than our ISO9001:2008 certification - we go even further. It's not just our standard, quality is our commitment.

TECHNOLOGY...

Technology change drives refractory development at a fast pace in today's highly charged manufacturing environment. URC is constantly developing new and improved refractory products to provide cost effective solutions for demanding industrial processes. Focused on customer needs, we develop novel refractory solutions to satisfy customer requirements.

SERVICE...

Customer demands are unique. Our customer service philosophy is as equally unique - true collaboration that defines courses of action which are both practical and goal-focused. Our dedicated technical staff regularly meets with operators and engineers to better understand their applications and needs. Our people work like our refractories - to assure that customers get the performance they need when they need it.

**UNITED REFRACTORIES CO.
CORPORATE OFFICE**

264 Valleybrook Road
McMurray, PA 15317 USA
Phone: (724) 941-9300
Fax: (724) 941-9690

**UNI-REF, INC.
MANUFACTURING FACILITY**

11301 Jefferson Avenue
Sharonville, OH 45241 USA
Phone: (513) 563-9955
Fax: (513) 563-1698

WWW.UNITEDREFRACTORIESCO.COM



Quality means more than
our ISO9001:2008
certification - we go even
further. It's not just our
standard, quality is our
commitment.